

DIN Rail RTU 530CID02

RTU530 product line



RTU530 base module with two Ethernet ports and integrated I/O

- Compact and robust design
- 2x serial ports (1x RS-232, 1x RS-485)
- 2x Ethernet interface (10/100BaseT)
- USB configuration interface
- Power supply input with 24 V DC
- Integrated I/O (8 binary inputs, 4 binary outputs)
- 24 - 60 V DC process voltage of the integrated I/O
- With interface to extension I/O-modules

Application

The 530CID02 is a module of the RTU530 product line consisting of a communication unit (CMU), a multi I/O module (IOM) and a power supply in a compact and robust DIN rail housing.

The essential tasks are:

- Managing and controlling of the RTU530 product line I/O modules via the serial I/O bus
- Reading Process events from the input modules.
- Send commands to the output modules.
- Communicating with control systems and local HMI systems via the serial interfaces and the Ethernet interfaces.
- Communication with Sub-RTU's, IED's or multimeter devices via the serial interfaces and the Ethernet interfaces.
- Managing the time base for the RTU530 product line station and synchronizing the I/O modules.

- Handling the dialog between RTU530 product line and Web-Browser via the LAN and USB interfaces.
- Capturing of 8 digital input signals
- 4 output contacts (normal open), 1 or 2 pole output
- Supply up to 10 RTU530 I/O modules with power (24 V / 5 V)

The communication unit is able to handle Ethernet- and UART character based communication protocols.

The unit is available in two versions:

- R0002: process voltage 24 ... 60 V DC, with crypto chip for high-demanding cyber security use cases
- R1002: process voltage 24 ... 60 V DC, with crypto chip for high-demanding cyber security use cases, conformal coated

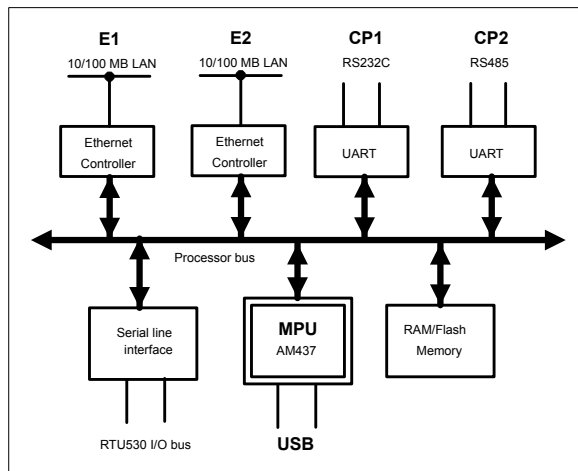

Figure 1: Block diagram communication unit

Characteristics

Communication unit

On the applied ARM cortex A9 controller AM437 a real-time operating system is implemented. The 530CID02 is responsible for the interface management, the event handling, the time base and the internal data base. The controller acts as master for the serial RTU530 I/O bus (IOB).

System relevant configuration files are stored on the embedded multi memory card in order to guarantee a valid system configuration after Power on Reset (PoR).

The communication unit provides the following interfaces:

- Communication Port 1 (CP1): a serial interface according RS232C with RJ45 connector.
- Communication Port 2 (CP2): serial interfaces according RS485 with RJ45 connector.
- Ethernet interface 1 and 2 (E1 & E2): 10/100BaseT with RJ45 connector.
- USB 2.0 device interface for diagnosis and maintenance purposes.

I/O controller (IOC)

The I/O micro-controller on the module processes all time critical I/O tasks of the parameterized processing functions. Moreover it carries out the interactive communication with the RTU530 I/O bus. All configuration data and processing parameters are loaded by the communication unit via the RTU530 I/O bus.

In connection with an I/O adapter (e. g. 530ADD01) or the RTU530 communication unit the module is interfaced to the RTU530 I/O bus.

The binary input unit can execute the following processing functions for the different types of signals:

- Digital filtering to suppress contact bounce
- Suppression of oscillating signals caused by the process
- Validity check and suppression of intermediate input states for double indications
- Consistency check for all channels allocated to digital measured values or step position information
- Summation of increment pulses to form integrated totals in registers of 31 bit resolution

- Copying of integrated totals values into freezing registers for data conservation

The binary output unit can execute the following processing functions on the individual signal types:

- Control of the command output duration

Command monitoring functions:

- monitoring of the output bit patterns by reading back the output state
- switching voltage monitoring (24 V DC coil voltage) before and during output
- command output duration monitoring

The module provides a data buffer for temporally storing of up to 50 event messages including time stamps. The events are stored in chronological order designated for transmission to the communication unit (CMU).

During initialization and operation the module carries out a number of tests. If a fault occurs it is reported to the communication unit. All fault conditions impairing the function of the module are displayed as common fault signal by a red LED. A failure of the connected module(s) is detected and signaled by the communication unit.

Binary input unit

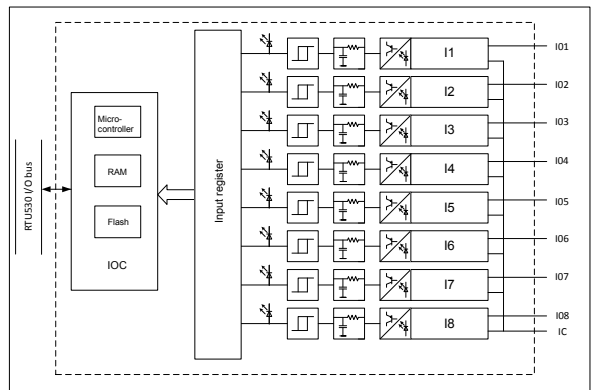

Figure 2: Block diagram binary input unit

The module 530CID02 of the RTU530 product line provides 8 galvanic isolated inputs for up to 8 binary process signals. Scanning and processing of the inputs are executed with the high time resolution of 1 ms. The allocation of an input signal to the processing functions can be done according to the rules of configuration.

The module 530CID02 is able to process the following types of signals or a combination of them:

- 8 single point information with time stamp (SPI)
- 4 double point information with time stamp (DPI)
- 1 digital measured values each with 8 bit (DMI8)
- 8 integrated totals (max. 120 Hz) (ITI)
- 1 step position information each with 8 bit (STI)
- 1 bitstring input each with 8 bit (BSI8)

The module allows process voltages from 24 to 60 V DC. LED signaling is available for all inputs. The module has a common return for all inputs.

The inputs are galvanic isolated by means of optical couplers.

The binary input channels are protected against reverse voltage installation. If the input signal is installed with wrong polarity the input current will be zero.

Binary output unit

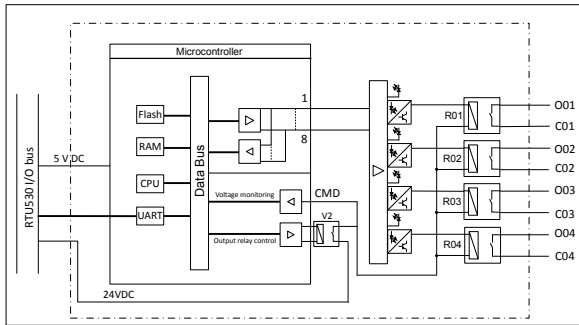

Figure 3: Block diagram binary output unit

The module 530CID02 of the RTU530 product line can be used for the control of 4 binary process signals using relay contacts. The allocation of an output signal to the processing functions can be done according to the rules of configuration.

The module 530CID02 is able to process the following types of signals:

- Single or double commands (SCO or DCO) with 1 or 2 pole output
- Regulation step command (RCO), 1 or 2 pole
- Bitstring output, 1 or 2 Bit (BSO1 or BSO2)

The module allows switching voltages up to 72 V DC or max. 5 A continuous current.

Relay contacts are used for the binary outputs.

The 4 outputs are isolated from one another and against the internal electronic. All 4 relay contacts have individual contacts without a common return.

The supply voltage for the coils of the relays (24 V DC) is switched by an internal switching transistor and is monitored internally before and during the command output.

Two output relays are required for each command in case of 2 pole commands.

Before and during command output the module 530CID02 carries out several command monitoring functions. These tests ensure correct output.

If the command monitoring detects a fault the command will be canceled.

Technical data

In addition to the RTU500 series general technical data, the following applies:

General standards

Safety tested according to	<ul style="list-style-type: none">IEC 61010-1IEC 61010-2-201
Environmental conditions tested according to	<ul style="list-style-type: none">IEC 60255-21-1 class 1IEC 60255-21-2 class 1IEC 60870-2-2 class Bm and C1
Electromagnetic compatibility (EMC) tested according to	<ul style="list-style-type: none">IEC 61000-6-2IEC 61000-6-4IEC 61000-6-5
Insulation classification according to	IEC 60664-1 <ul style="list-style-type: none">Pollution degree 2Overvoltage category IIAltitude: ≤ 3,000 m

Environmental conditions - climatic

Operating temperature EN 60068-2-14	-25 °C ... 70 °C
Start up EN 60068-2-1	-40 °C
Max. operating temperature, max. 96h EN 60068-2-2	+85 °C
Relative humidity EN 60068-2-30	5 ... 95 % (non condensing)

Environmental conditions - mechanical

Vibration sinusoidal, Test Fc, IEC 60068-2-6	3.5 mm (3...9 Hz) 10 m/s ² (9...35 Hz) 1 octave/ min, 1 cycle per axis IEC 60255-21-3 class 1
	3 mm (3...9 Hz) 10 m/s ² (9...200 Hz) 15 m/s ² (200...500 Hz) 1 octave/ min, 10 cycles per axis IEC 60870-2-2 class Bm
	0.035 mm (10 Hz...60 Hz) 5 m/s ² (60 Hz...150 Hz) 1 octave/ min, 1 cycle per axis IEC 60255-21-1 class 1
Shock and Bump, Test Ea, IEC 60068-2-27	250 m/s ² , 10 ms 4 shocks per direction IEC 60721-3-3 class 3M5
	150 m/s ² , 11 ms 3 shocks per direction IEC 60255-21-2 class 1 IEC 60870-2-2 class Bm
	100 m/s ² , 16 ms 1000 shocks per direction IEC 60255-21-2 class 1

Emission test

Radiated emissions - enclosure ports (30 Mhz to 1 GHz), CISPR 16-2-3/ EN 55016-2-3	EN 55011/ CISPR 11 class A
--	----------------------------

Immunity test

Electrostatic discharge, IEC 61000-4-2	8 kV air / 6 kV contact (level 3), criterion A
Radiated radio-frequency electromagnetic field, IEC 61000-4-3	80 MHz to 1 GHz: 10 V/m (level 3), criterion A 1 GHz to 2.7 GHz: 10 V/m (level 3), criterion A
Power frequency magnetic field, IEC 61000-4-8	100 A/m (level 5), criterion A
Impulse magnetic field, IEC 61000-4-9	100 A/m (level 3), criterion A

Mean time between failure (MTBF)

Calculation according to Telcordia III 40°C	1,265,550 h
---	-------------

Mechanical layout

Dimensions	60 mm x 125 mm x 85 mm (Width x Height x Depth)
Housing type	Plastic housing (V-2), RAL 7035 light gray
Mounting	DIN rail mounting (EN 50022 TS35: 35 mm x 15 mm or 35 mm x 7.5 mm)
Enclosure protection class	IP30
Weight	0.3 kg

Conformal coating

Material base	Acrylate resins (AR)
Standards	<ul style="list-style-type: none">IPC-CC-830BMIL-I-46058CUL 94UL 746E
Noxious gas protection (coating material)	noxious gas test according to DIN EN 60068-2-60 or BMW GS 95003-4
Dielectric strength (coating material)	60 kV/ mm according to IPC-TM-650 or DIN EN 60243-1
Resistance to condensation (coating material)	1.0 x 10 ¹⁰ Ohm based on DIN EN ISO 6270-2

Connection type

Process connector (X4)	1 x 17 pole 5.08 mm pluggable screw terminals (included in delivery), 0.2... 2.5 mm ² / AWG 24 - AWG 12
Power supply input (X1)	1 x 3 pole 5.08 mm pluggable screw terminals (included in delivery), 0.2... 2.5 mm ² / AWG 24 - AWG 12

Connection type	
Connector to the I/O modules (X3)	2 x 6 pin, female

Main Processing Unit MPU

CPU	Cortex A9, AM4372B @ 600 MHz
RAM	256 MByte
eMMC	4 GByte
SRAM	128 kByte

embedded MMC

Type	Kingston EMMC04G-W627-E01U
Capacity	4 GByte

Signaling by LEDs

ERR (red)	ON: RTU in error state
	Flashing: RTU in warning state
	For more details see RTU500 series Function Description
RUN (green)	Communication module in operation
	Flashing: Communication module in recovery mode
T	Transmit data on serial communication ports CP
R	Receive data on serial communication ports CP
S	Ethernet communication speed:
	ON: 100 Mbit/s
	OFF: 10 Mbit/s
L	Link up (ON) / Activity (Flashing) on Ethernet interface E
I1... I8	LED displays the active inputs
O1... O4	LED displays the active output relays

Power supply input (X1)

Input voltage	24 V DC
Input tolerance range	-20%...+20%
Power consumption (typical)	32 W
Current demand (peak)	2.0 A
Starting current	<20 A; 50µs - 1.5ms (Class S1 according to IEC 60870-4)
Plug type	1 x 3 pole 5.08 mm pluggable screw terminals (included in delivery), 0.2... 2.5 mm ² / AWG 24 - AWG 12

Power supply input (X1)

Reverse polarity protection	yes
Input fuse	internal fuse
External circuit-breaker	10 A trip current, the plus lead needs a be protected by a circuit-breaker
Galvanic isolation	no

Power supply input - immunity, emission and insulation tests

Electrical fast transient / Burst, IEC 61000-4-4	4 kV (level 4), criterion A
Surge 1.2/50 µs, IEC 61000-4-5	4 kV line to earth (level 4), 1 kV line to line, criterion A
Conducted disturbances, induced by radio-frequency fields, IEC 61000-4-6	10 V (level 3), criterion A
Ring wave, IEC 61000-4-12	2.5 kV line to earth, 1 kV line to line (level 3), criterion A
Conducted, common mode disturbances in the frequency range 0 Hz to 150 kHz, IEC 61000-4-16	30 V continuous disturbance/ 300 V short duration disturbance (level 4), criterion A
Ripple on DC power supply, IEC 61000-4-17	20% Un
Damped oscillatory wave, IEC 61000-4-18	2.5 kV line to earth, 1 kV line to line @ 1 MHz (level 3), criterion A
Conducted emissions - asymmetrical DC ports, common mode (0.15 MHz to 30 MHz), CISPR 16-2-1/ EN 55016-2-1	EN 55011/ CISPR 11 class A
Inverted polarity and voltage ramp delay, IEC 60255-27	1 V/ min

Current supply for power supplied via RTU530 I/O bus

5 V DC (± 5%)	1.45 A
24 V DC (± 20%)	1.475 A

Ethernet interfaces (E1, E2)

Electrical specification	IEEE 802.3
Protocol	Fast Ethernet, Auto negotiation, Auto sense
Data rate	100 Mbps, 10 Mbps or auto
Duplex	full duplex, half duplex or auto
Transmission / Network termination	MDI, MDI-X or auto
Cable	shielded CAT5e cable (or better), maximum length: 100m
Plug type	RJ-45 (8P8C)
Galvanic isolation	1.5 kV isolation voltage
Electrical fast transient / Burst, IEC 61000-4-4	4 kV (level 4), criterion A
Surge 1.2/50 µs, IEC 61000-4-5	4 kV (level 4), criterion A

Ethernet interfaces (E1, E2)	
Conducted disturbances, induced by radio-frequency fields, IEC 61000-4-6	10 V (level 3), criterion A
Ring wave, IEC 61000-4-12	2.5 kV (level 3), criterion A
Conducted, common mode disturbances in the frequency range 0 Hz to 150 kHz, IEC 61000-4-16	30 V continuous disturbance/ 300 V short duration disturbance (level 4), criterion A
Damped oscillatory wave, IEC 61000-4-18	2.5 kV (level 3), criterion A
Conducted emissions - symmetrical network ports (0.15 MHz to 30 MHz), CISPR 16-2-1/ EN 55016-2-1	EN 55032/ CISPR 32 class A

Serial interfaces (CP1, CP2)	
Electrical specification	CP1: EIA RS-232, CP2: EIA RS-485
Data rate	CP1: 200 bps... 38.4 kbps, CP2: 200 bps... 1000 kbps
Plug type	RJ-45 (8P8C)
Cable	shielded cable, up to 3 m (RS-232), up to 50m (RS-485)
Electrical fast transient / Burst, IEC 61000-4-4	4 kV (level 4), criterion A
Surge 1.2/50 μ s, IEC 61000-4-5	4 kV (level 4), criterion A
Conducted disturbances, induced by radio-frequency fields, IEC 61000-4-6	10 V (level 3), criterion A
Ring wave, IEC 61000-4-12	2.5 kV (level 3), criterion A
Conducted, common mode disturbances in the frequency range 0 Hz to 150 kHz, IEC 61000-4-16	30 V continuous disturbance/ 300 V short duration disturbance (level 4), criterion A
Damped oscillatory wave, IEC 61000-4-18	2.5 kV (level 3), criterion A

USB interface	
Connector	micro USB Type B (female)
Type	USB 2.0 device, low, full and high speed (max. 480 MBit/s)
Cable type to PC	USB Type A <-> micro USB Type B

Binary input channels	
Inputs	8 channels, 1 common return for all channels, isolated by opto-couplers
Nominal input voltage	24... 60 V DC (+/- 20%)
Max. input voltage	72 V DC
Input current	1.2... 5 mA

Binary input channels	
Logical '1' definitely detected	≥ 18 V DC
Logical '0' definitely detected	≤ 9 V DC
Reverse voltage protection	yes
Max. input frequency for integrated totals	120 Hz

Binary inputs - immunity and insulation tests	
Electrical fast transient / Burst, IEC 61000-4-4	4 kV (level 4), criterion A
Surge 1.2/50 μ s, IEC 61000-4-5	4 kV line to earth, 2 kV line to line (level 4), criterion A
Conducted disturbances, induced by radio-frequency fields, IEC 61000-4-6	10 V (level 3), criterion A
Ring wave, IEC 61000-4-12	2.5 kV line to earth, 1 kV line to line (level 3), criterion A
Conducted, common mode disturbances in the frequency range 0 Hz to 150 kHz, IEC 61000-4-16	30 V continuous disturbance/ 300 V short duration disturbance (level 4), criterion A
Damped oscillatory wave, IEC 61000-4-18	2.5 line to earth, 1 kV line to line (level 3), criterion A
AC dielectric voltage test, IEC 60255-27, IEC 61000-4-16, IEC 60870-2-1 (class VW3)	2.5 kV, 50 Hz, 1 min
Impulse voltage withstand test of insulation, IEC 60255-27, IEC 60870-2-1 (class VW3)	5 kV (1.2 / 50 μ s)
Insulation resistance, IEC 60255-27	> 50 M Ω @ 500 V DC

Binary output channels 530CID02	
Outputs	4 Relay contacts, single pole, normal open
Coil voltage	24 V DC @ 10 mA
Max. switching voltage	72 V DC
Continuous current	5 A
Max breaking current (resistive load)	5 A \leq 30 V DC 1 A @ 60 V DC
Max. breaking capacity (inductive load)	50 VA (L/R= 40 ms)
AC dielectric voltage test, IEC 60255-27, IEC 61000-4-16, IEC 60870-2-1 (class VW3)	2.5 kV, 50 Hz, 1 min
Impulse voltage withstand test of insulation, IEC 60255-27, IEC 60870-2-1 (class VW3)	5 kV (1.2 / 50 μ s)
Insulation resistance, IEC 60255-27	> 50 M Ω @ 500 V DC
Electrical fast transient / Burst, IEC 61000-4-4	4 kV (level 4), criterion A
Surge 1.2/50 μ s, IEC 61000-4-5	4 kV line to earth, 2 kV line to line (level 4), criterion A

Binary output channels 530CID02

Conducted disturbances, induced by radio-frequency fields, IEC 61000-4-6	10 V (level 3), criterion A
Ring wave, IEC 61000-4-12	2.5 kV line to earth, 1 kV line to line (level 3), criterion A
Conducted, common mode disturbances in the frequency range 0 Hz to 150 kHz, IEC 61000-4-16	30 V continuous disturbance/ 300 V short duration disturbance (level 4), criterion A
Damped oscillatory wave, IEC 61000-4-18	2.5 kV line to earth, 1 kV line to line (level 3), criterion A

Ordering information

530CID02 R0002	1KGT050900R0002
----------------	-----------------

process voltage 24 ... 60 V DC, with crypto chip for high-demanding cyber security use cases

530CID02 R1002	1KGT050900R1002
----------------	-----------------

process voltage 24 ... 60 V DC, with crypto chip for high-demanding cyber security use cases, conformal coated

ABB Power Grids Germany AG

P.O. Box 10 03 51
68128 Mannheim, Germany

hitachiabb-powergrids.com/rtu

We reserve the right to make technical changes or modify the contents of this document without prior notice. With regard to purchase orders, the agreed particulars shall prevail. Hitachi ABB Power Grids does not accept any responsibility whatsoever for potential errors or possible lack of information in this document.

We reserve all rights in this document and in the subject matter and illustrations contained therein. Any reproduction, disclosure to third parties or utilization of its contents – in whole or in parts – is forbidden without prior written consent of Hitachi ABB Power Grids.
© 2021 Hitachi Power Grids
All rights reserved

ABB is a registered trademark of ABB Asea Brown Boveri Ltd. Manufactured by/ for a Hitachi Power Grids company.